

SCHEMATIC DIAGRAM

REMARKS	PARTS NAME
NO MARK	CARBON FILM RESISTOR (P-5)
△	CARBON FILM RESISTOR (P-10)
□	METAL OXIDE FILM RESISTOR
◇	METAL FILM RESISTOR
○	METAL PLATE RESISTOR
○	FIRE PROOF CARBON FILM RESISTOR
○	CEMENT MOLDED RESISTOR
○	SEMIVARIABLE RESISTOR
○	CHIP RESISTOR

The voltages are measured using normal tape in the PLAY mode (no-signal condition). Only the voltage in () are in the REC mode.

各電圧は、ノーマルテープで再生時の電圧です。ただし、()の電圧は録音時の電圧です。

REMARKS	PARTS NAME
NO MARK	ELECTROLYTIC CAPACITOR
△	TANTALUM CAPACITOR
○	CERAMIC TUBULAR CAPACITOR
○	POLYESTER FILM CAPACITOR
○	POLYETHYLENE FILM CAPACITOR
○	MICA CAPACITOR
○	POLYPROPYLENE FILM CAPACITOR
○	SEMICONDUCTIVE CERAMIC CAPACITOR

NOTICE (model)
(J)..... JAPANESE
(U)..... U.S.A
(C)..... CANADIAN
(R)..... GENERAL
(A)..... AUSTRALIAN
(B)..... BRITISH
(G)..... EUROPEAN
(T)..... CHINA
(L)..... SINGAPORE

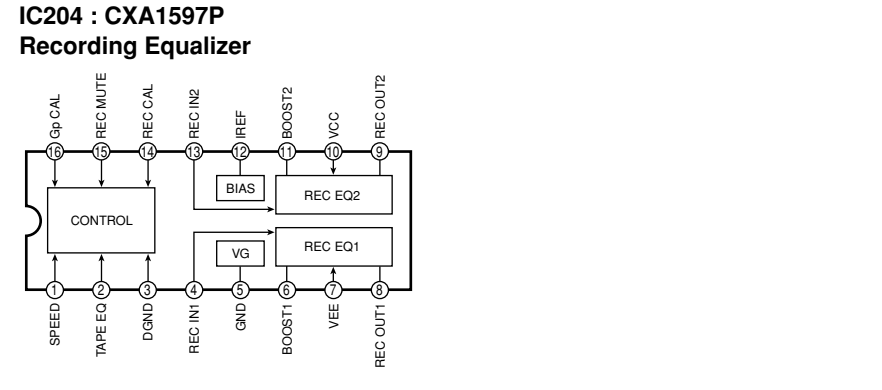
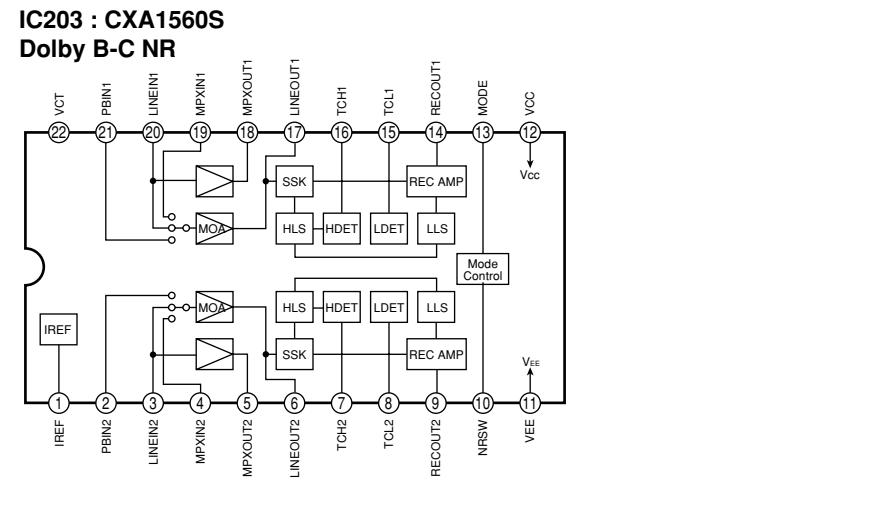
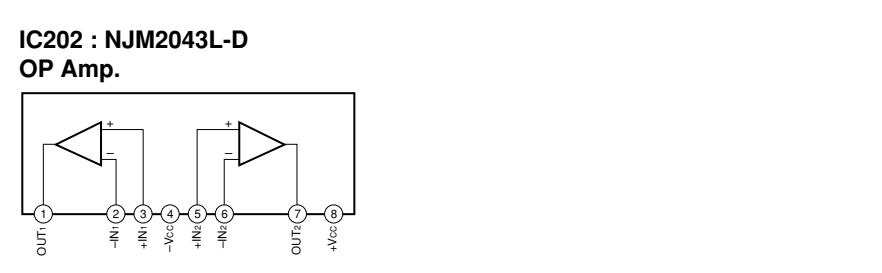
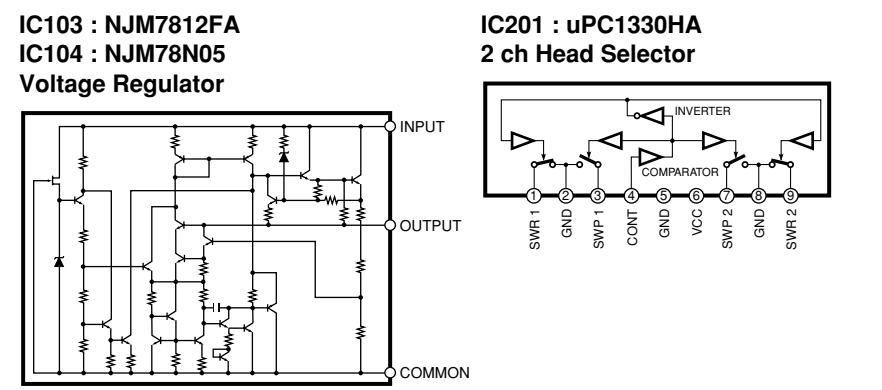
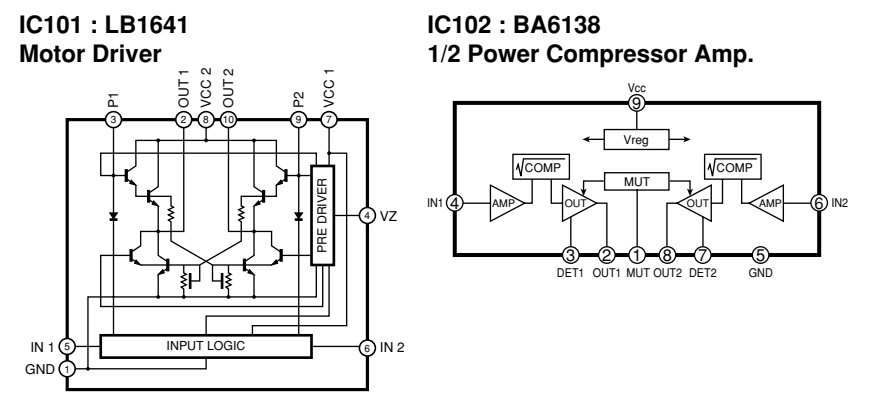
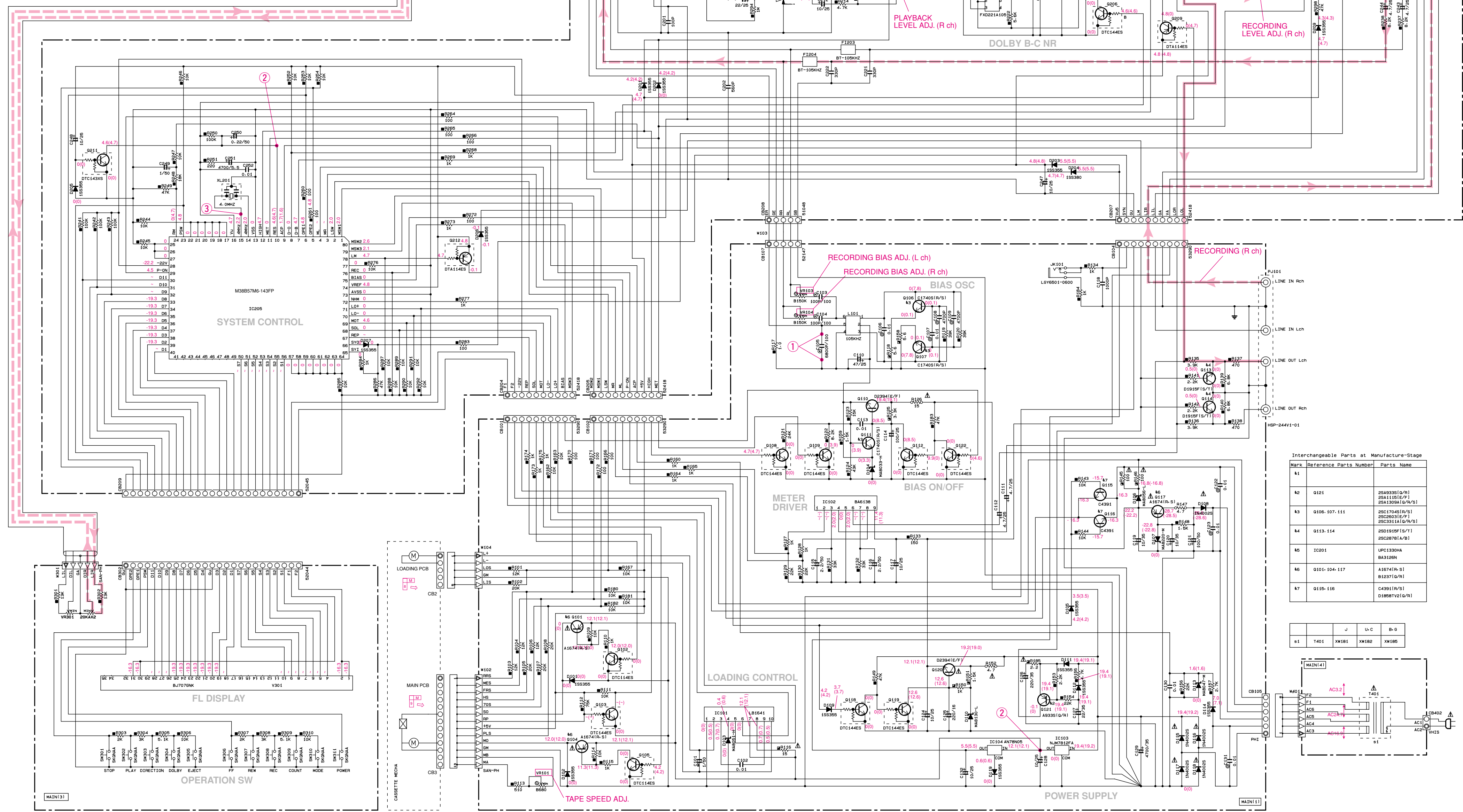

Interchangeable Parts at Manufacture-Stage

Mark	Reference	Parts Number	Parts Name
K1	G101	2S49351(G/R)	2S49351(G/R)
K2	G101	2S49351(G/R)	2S49351(G/R)
K3	G106, 507, 511	2SC17045(R/S)	2SC17045(R/S)
K4	G133, 514	2SC1915P(S/T)	2SC1915P(S/T)
K5	IC201	uPC1330HA	uPC1330HA
K6	G101, 104, 117	A187416-B1	A187416-B1
K7	G150, 116	C439114/R1	D1887V2(G/R)

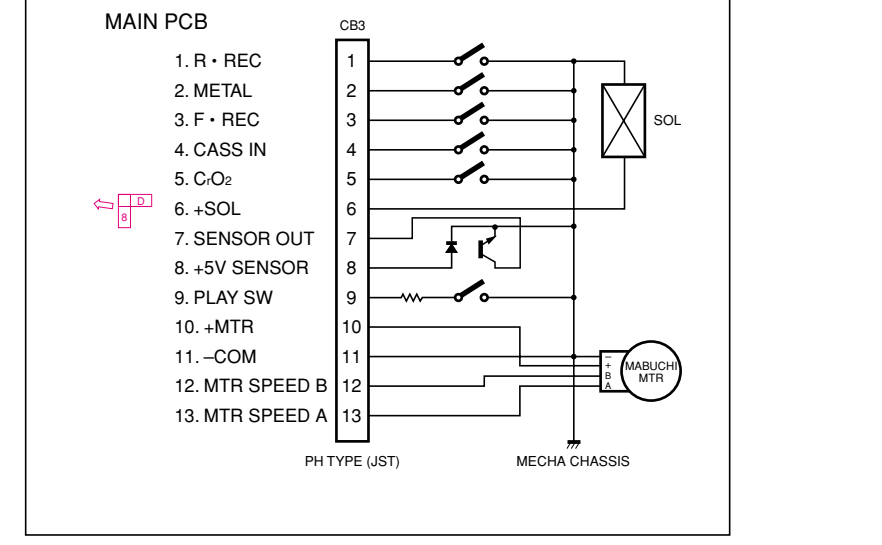
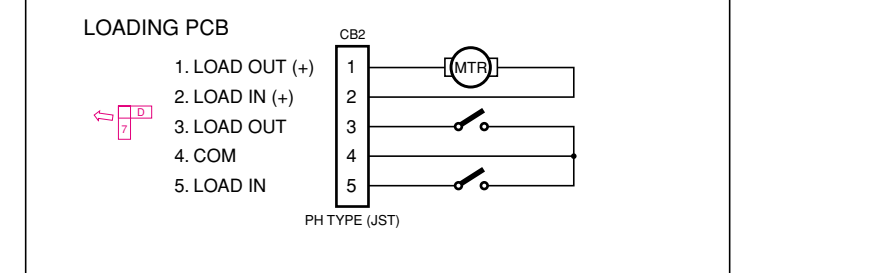
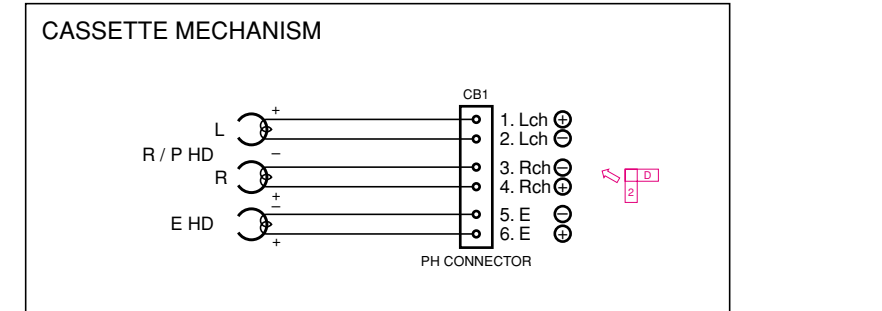

PIN CONNECTION OF TRANSISTORS, DIODES AND ICs.

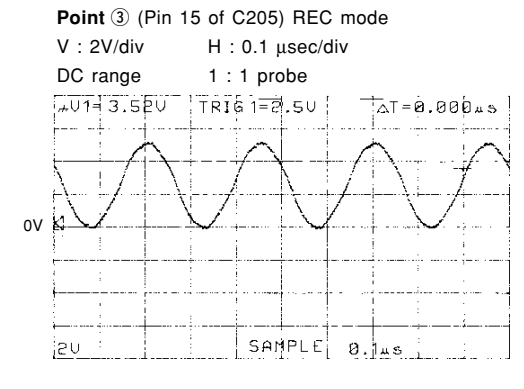
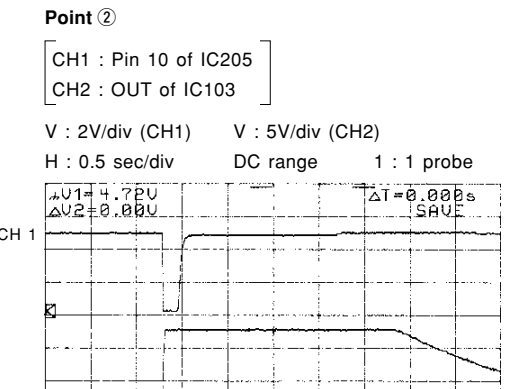
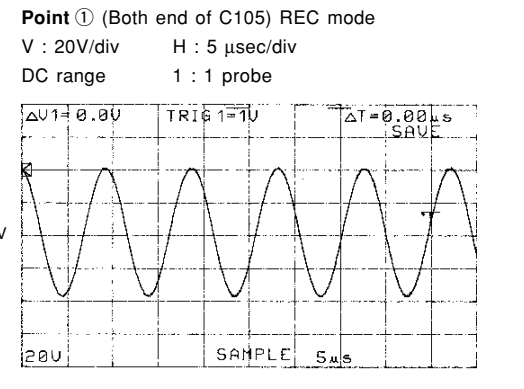
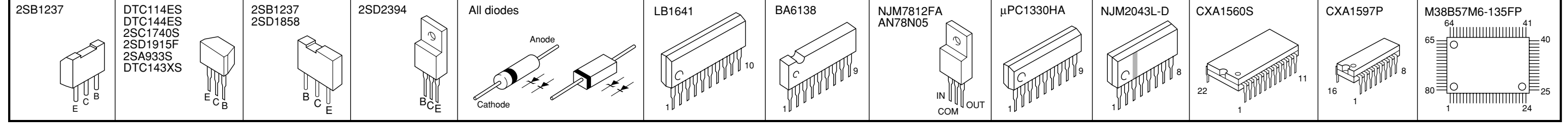

* All voltage are measured with a 10MΩ/V DC electric volt meter.
△印のある部品は、安全性確保部品を示しています。部品の交換が必要な場合、パーツリストに記載されている部品を使用してください。
本回路図は、標準回路図です。改良のため予告なく変更することがございます。